

# MPEG4000XLP

## 4-Channel MPEG-4 Codec for PC/104-Plus



**Advanced Micro  
Peripherals**

THE EMBEDDED VIDEO EXPERTS

The MPEG4000XLP is a 4-channel MPEG-4 Codec on a single PC/104-Plus form factor. It provides a low power and high performance solution for capturing and compressing up to 4 concurrent analog video inputs to MPEG-4 standard.



The MPEG4000XLP utilizes 32-bit PCI architecture to perform high quality real-time video and audio capture and compression from up to 4 concurrent PAL or NTSC video sources to disk whilst at the same time allowing incoming video to be previewed on the host screen.

In addition to providing MPEG-4 compression the MPEG4000XLP can decompress and replay stored recordings, and text and graphic annotation can be alpha-blended with the incoming video.

The high performance and reduced bus utilization of the MPEG4000XLP allows up to four cards to be combined in a PC/104-Plus system to channel up to 16 concurrent video streams to disk or across a network.

The MPEG4000XLP is supported by a suite of drivers for Windows-NT/2000/XP, Linux and QNX.

Records up to  
four concurrent  
PAL/NTSC  
channels

**Advanced Micro Peripherals Ltd**  
Cambridge, CB6 2HY, England  
Tel (+44) 1353 659500  
Fax (+44) 1353 659600  
[sales@ampltd.com](mailto:sales@ampltd.com)  
<http://www.ampltd.com>

**Advanced Micro Peripherals Inc**  
New York, NY10001, USA  
Tel (+1) 212 951 7205  
Fax (+1) 212 951 7206  
[sales@amp-usa.com](mailto:sales@amp-usa.com)  
<http://www.amp-usa.com>



# MPEG4000XLP

4-Channel MPEG-4 Codec for PC/104-Plus



**Advanced Micro  
Peripherals**

THE EMBEDDED VIDEO EXPERTS



Low power

MPEG-4

playback

to

PAL/NTSC

## Applications

Medical Archiving

Vehicle-based Video Codec

Remote Video Surveillance

Video Acquisition and Analysis

Traffic Monitoring and Control

Solid-State Digital Video Recorder

Multi-Camera Security Application

Intranet/Internet Video Streaming

## Advanced Micro Peripherals Ltd

Cambridge, CB6 2HY, England

Tel (+44) 1353 659500

Fax (+44) 1353 659600

[sales@amp ltd.com](mailto:sales@amp ltd.com)

<http://www.amp ltd.com>

## Advanced Micro Peripherals Inc

New York, NY10001, USA

Tel (+1) 212 951 7205

Fax (+1) 212 951 7206

[sales@amp-usa.com](mailto:sales@amp-usa.com)

<http://www.amp-usa.com>



# MPEG4000XLP

## 4-Channel MPEG-4 Codec for PC/104-Plus

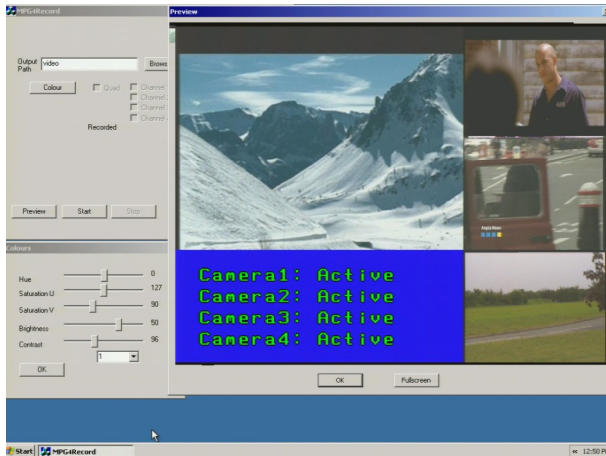

### Simultaneous Preview & Playback

Text overlay on  
preview and  
recording

### Features

MPEG-4 Decode/Playback

4 Asynchronous Live NTSC/PAL Inputs

Up to 4 MPEG4000XLP cards per system

Video Preview to System VGA, PAL/NTSC

Low Power rugged PC/104-Plus Form Factor

1 x D1 size MPEG-4 Encode at full frame rate

4 x D1 size MPEG-4 Encode at 1/4 frame rate

4 x CIF size MPEG-4 Encode at full frame rate

Drivers for Win-NT/2000/XP-E, Linux, QNX

Text Overlay, eg time and date stamp

**Advanced Micro Peripherals Ltd**  
Cambridge, CB6 2HY, England  
Tel (+44) 1353 659500  
Fax (+44) 1353 659600  
[sales@amp ltd.com](mailto:sales@amp ltd.com)  
<http://www.amp ltd.com>

**Advanced Micro Peripherals Inc**  
New York, NY10001, USA  
Tel (+1) 212 951 7205  
Fax (+1) 212 951 7206  
[sales@amp-usa.com](mailto:sales@amp-usa.com)  
<http://www.amp-usa.com>



### Video Recording Modes

MPEG4000XLP supports two main modes of video recording: Split Video Stream and Combined Video Stream.

### Split Video Stream

In the Split Video Stream (SVS) mode the multiple channels being previewed are captured and recorded as separate files or streams. The MPEG4000XLP will output four files - one per channel. These streams are independent and can subsequently be played back as totally independent MPEG-4 streams by appropriate hardware/software decoders or through the playback feature of the MPEG4000XLP.

The SVS mode supports 2 sub modes:

- 4 x CIF size MPEG-4 each at full frame rate;
- 4 x D1 size MPEG-4 each at lower frame rate

When set for 4 x CIF, the 4 inputs can be concurrently recorded each at full frame rate. Each channel is first decimated to quarter

screen size prior to encoding. This results in sizes of 352x240 for NTSC and 352x288 for PAL.

The 4 x D1 sub-mode allows 4 inputs to be recorded each at full D1 size with input at less than full frame rate. 4 full D1 size (up to 720x480 for NTSC and 720x576 for PAL) video is recorded in this mode.

In the Split Video Stream mode, encoding parameters (such as bit rate and motion detection) can be set separately and independently for each video source.

### Combined Video Stream

When set for Combine Video Stream (CVS), the four video channels being previewed are recorded as a single MPEG-4 file as if they were coming from a single video source. There is no separation and the resulting MPEG-4 file can subsequently be played back as single MPEG-4

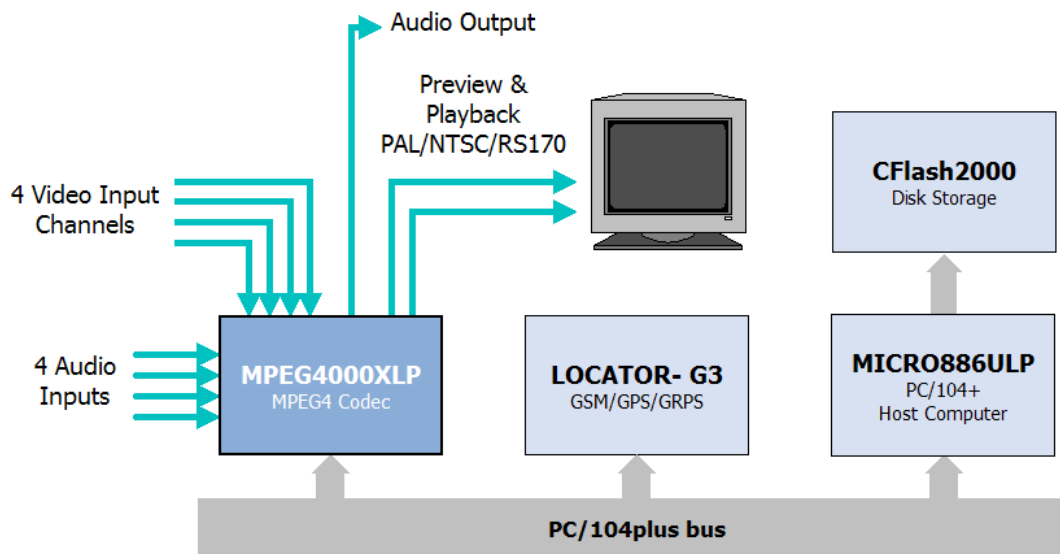

**Mobile MPEG-4 Record and Playback System**

# MPEG4000XLP

## 4-Channel MPEG-4 Codec for PC/104-Plus

## Operation Summary

stream by the MPEG4000XLP or appropriate hardware/software decoders.

### Video Setting

The MPEG4000XLP supports PAL and NTSC video input. The required standard is software selectable.

In applications where recording space is restricted the MPEG4000XLP provides additional flexibility by supporting a range of capture frame rates at or below the standard video rates (30/25fps NTSC/PAL). For NTSC, the Frame Rate can be set to 30, 15, 7.5, 3.75, etc down to 0.9375 fps. For PAL, the supported frame rates include 25, 12.5, 6.25, etc down to 0.7813 fps. The lower frames rates in each case are derived by successive division by 2.

### I/P Frame Encoding

The MPEG4000XLP supports encoding of both I and P frames. Encoding of only I frames is also supported. The supported I intervals are 2, 4, 8, 16 up to 256 with the default being 64.

### Encoding Bit Rate Control

The MPEG4000XLP provides flexible bit rate control by providing three modes including Variable Bit Rate (VBR), Constant Bit Rate (CBR) and Hybrid Bit Rate (HBR)

### Variable Bit Rate (VBR)

For VBR, the Quantization value can be set from 1 to 31 with 10 as the default. In VBR the picture quality is fixed with fixed quantization value and the bit rate varies automatically in reaction to the incoming video to maintain the set quality. VBR is appropriate for storage applications.

### Constant Bit Rate (CBR)

In CBR Mode, the average bit rate is fixed and the picture quality is automatically adjusted by the MPEG4000XLP on a frame-by-frame basis to maintain the pre-set average bit rate.

CBR is of particular benefit where video needs to be streamed over a fixed-bandwidth link.

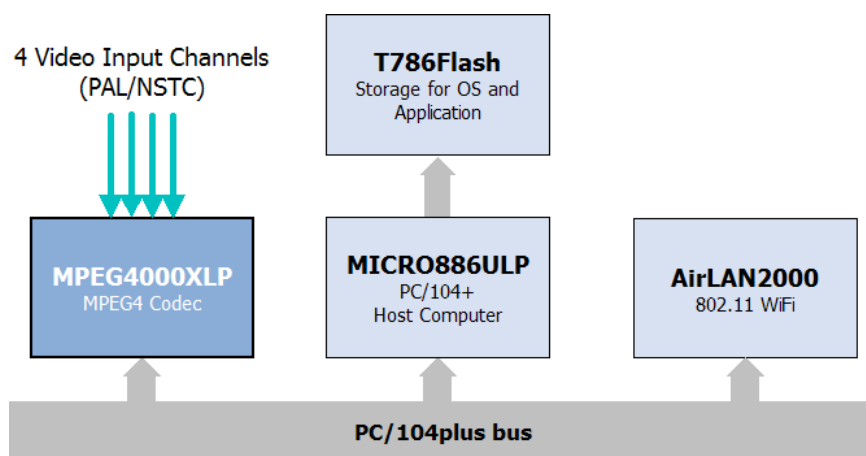

**Wireless Video Telemetry System**



# MPEG4000XLP

## 4-Channel MPEG-4 Codec for PC/104-Plus

## Operation Summary

### Hybrid Bit Rate (HBR)

HBR is a combination of VBR and CBR in which the MPEG4000XLP dynamically adjusts the bit rate between preset maximum and minimum values.

### Motion Detection and Event Triggers

The MPEG4000XLP supports automatic motion detection on a per channel basis. Motion detection parameters such as frame difference threshold and number of frames can be set independently per video channel.

Using the motion-detection feature, the MPEG4000XLP can be operated in a babysitting mode where recording is committed to disk only when scene motion event is detected, to make most efficient use of disk storage.

Software for the MPEG4000XLP allows recording of pre-trigger, on-trigger and post-trigger events.

### Video Preview

The MPEG4000XLP provides a secondary video path allowing the video being recorded to be streamed to host systems VGA buffer for video previewing. The Preview output can also be used to view an alternate video source while recording other inputs. The Preview information is also available as a composite PAL/NTSC output suitable for driving a PAL/NTSC or RS170 display device.

### OSD Video Text Overlay

The MPEG4000XLP has a text overlay feature which allows text such as time-stamp to be overlaid on incoming video prior to recording. This is a useful feature for applying real-time annotation and labelling to Preview and MPEG-4 recordings.

The MPEG4000XLP provides various layers of overlay such as character, box overlay and mouse pointer which can be overlaid on Preview and Record paths independently.

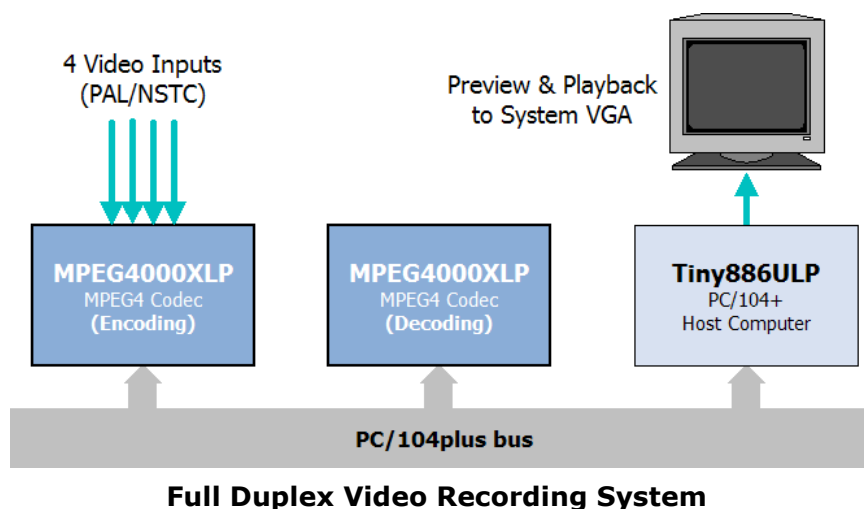

# MPEG4000XLP

## 4-Channel MPEG-4 Codec for PC/104-Plus

## Operation Summary

Video source information such as camera reference, location, time and date stamp, etc can be overlaid on both preview and recordings.

In addition to playback to the system display VGA device, the MPEG4000XLP also provides a composite PAL/NTSC playback output suitable for directly driving a PAL/NTSC or RS170 display device.

### MPEG-4 Decode and Playback

The MPEG4000XLP supports decoding and playback of MPEG-4 files from storage to the host system's display screen. Maximum image size of decoded video is 720x480 (NTSC) or 720x576 for PAL. Audio data which is part of the original recording is also decoded and played back in synchronization with the video.

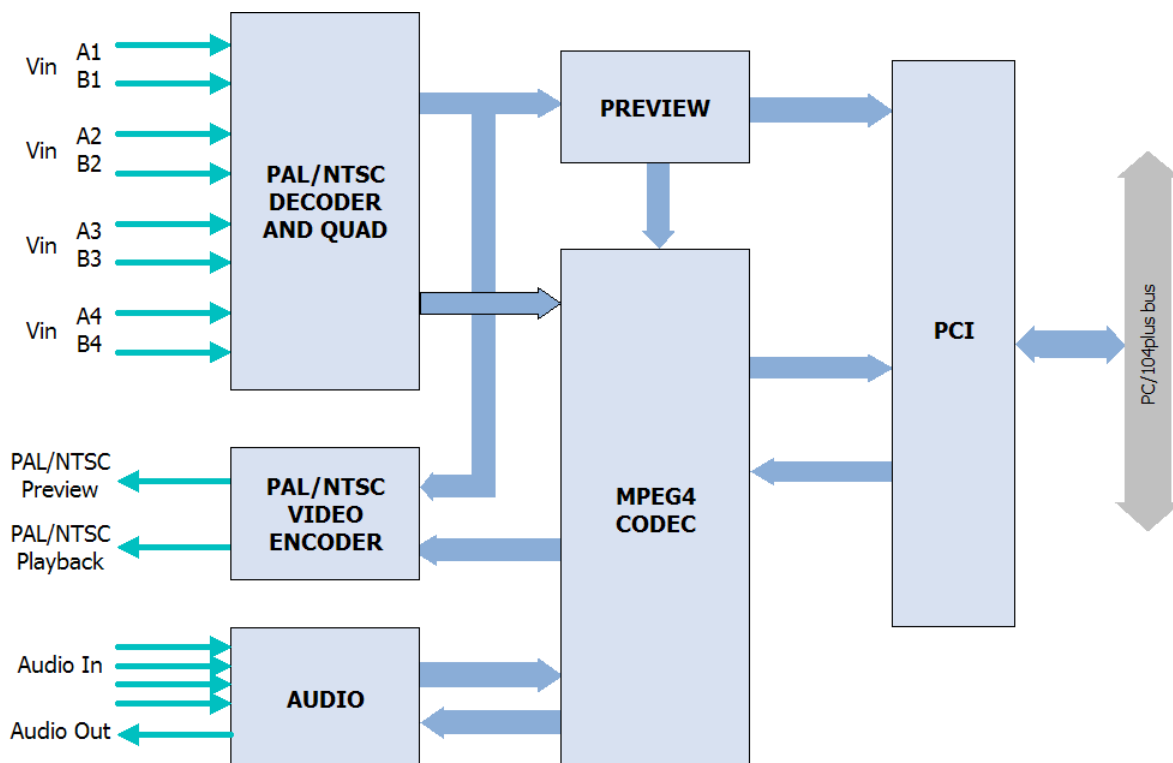

**MPEG4000XLP Block Diagram**



**PC/104-Plus Bus Interface**

Compliant with PCI Rev 2.1  
 132MBytes/sec bandwidth at 33.33 MHz bus speed  
 Live multi-stream MPEG4 capture to memory or disk  
 Concurrent MPEG-4 Capture and live preview

**Analog Video Input**

Up to 4 concurrent composite PAL or NTSC video input channels  
 Two input video multiplexer per Channel (up to 8 cameras)  
 Four 10-bit Analog-to-Digital converters  
 Anti-aliasing filters on inputs

**Video Input Formats**

Standard CCIR601-NTSC, CCIR-PAL  
 NTSC-M, NTSC-Japan  
 PAL-B, PAL-D, PAL-G, PAL-H, PAL-I, PAL-M, PAL-N

**Video Input Adjustments**

Contrast (or luma gain) adjustable from 0 - 200% of original  
 Saturation (or chroma gain) adjustable from 0 - 200% of original  
 Hue (or chroma phase) adjustable from -180 to +180  
 Brightness (or luma level) can be adjusted from 0 - 255 steps

**Audio Input**

Voice quality mono or microphone sound input per channel (1Vrms)  
 Provides Audio/Video Synchronization  
 Supports ADPCM PCM at 32KBits/sec per channel  
 64Kbps muLaw

**Video Encoding**

Real-time MPEG-4 Video Encoding (ISO/IEC 14496-2, MPEG-4 ASP at Level 5)  
 1 channel NTSC full D1 ( 720 x 480) at 30fps  
 4 channels NTSC CIF (352 x 240) at 120fps  
 1 channel PAL full D1 ( 720 x 576) at 25fps  
 4 channels PAL CIF (352 x 288) at 100fps  
 4 channels PAL/NTSC full D1 at reduced frame rates  
 Supports I, P and B Frame Compression  
 Supports Variable Bit Rate (VBR)  
 Supports Constant Bit Rate (CBR)  
 Support Hybrid Bit rate (HBR)

**Video Decoding / Playback**

Real-time MPEG-4 Video Decoding  
 ISO/IEC 14496-2, MPEG-4 ASP at Level 5  
 Playback to Composite PAL/NTSC output

**Uncompressed Video Path**

Real-time Preview to host VGA display  
 Preview to Composite PAL/NTSC output

**Motion Detection**

1350 (NTSC) or 1620 (PAL) detection blocks  
 Masking of areas not required for motion detection  
 Adjustable sensitivity

**Text/Graphics overlay**

4 color character/bitmap overlay  
 4 level alpha-blending  
 16 font, 128 glyph memory  
 675 (NTSC) or 810 (PAL) graphics blocks

**System Requirements**

x86 PC-Compatible PC/104-Plus Computer  
 PCI or AGP Display (if Video Preview to host is required)  
 Spare REQ/GNT on PC/104-Plus bus  
 3.3V signalling PC/104-Plus bus

**Miscellaneous**

Single +5V at less than 1.25A  
 Operating temp 0°C to 60°C  
 Extended temperature -40°C to +85°C (option)  
 Standard 3.6 x 3.8in PC/104-Plus form factor

**Software Drivers**

Drivers for Windows-NT/2000/XP, Linux, QNX  
 Sample video recording application in C/C++ source code

**Related Products**

MP4XLP-VTelemetry      Low Latency Video Telemetry SDK  
 MP4XLP-VSteam          RTSP Video Streaming SDK

**Ordering Information**

MPEG4000XLP              MPEG-4 Video Codec (0 to 60°C)  
 MPEG4000XLP-Ext        MPEG-4 Video Codec (-40°C to +85°C)

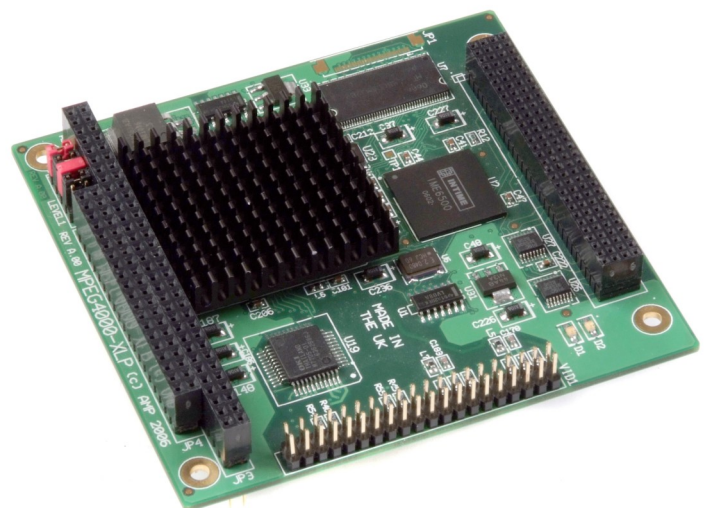
**MPEG4000XLP**